

## FEATURES

- Integrated NV SRAM, Real-Time Clock, Crystal, Power-Fail Control Circuit, and Lithium Energy Source
- Clock Registers are Accessed Identically to the Static RAM. These Registers are Resident in the Eight Top RAM Locations.
- Century Byte Register (i.e., Y2K Compliant)
- Totally Nonvolatile with Over 10 Years of Operation in the Absence of Power
- BCD-Coded Century, Year, Month, Date, Day, Hours, Minutes, and Seconds with Automatic Leap-Year Compensation Valid Up to the Year 2100
- Battery Voltage-Level Indicator Flag
- Power-Fail Write Protection Allows for  $\pm 10\%$   $V_{CC}$  Power-Supply Tolerance
- Lithium Energy Source is Electrically Disconnected to Retain Freshness Until Power is Applied for the First Time
- DIP Module Only  
Standard JEDEC Byte-Wide 32k x 8 Static RAM Pinout
- PowerCap<sup>®</sup> Module Board Only  
Surface-Mountable Package for Direct Connection to PowerCap Containing Battery and Crystal  
Replaceable Battery (PowerCap)  
Power-On Reset Output  
Pin-for-Pin Compatible with Other Densities of DS174xP Timekeeping RAM
- Also Available in Industrial Temperature Range:  $-40^{\circ}\text{C}$  to  $+85^{\circ}\text{C}$
- UL Recognized

## PIN CONFIGURATIONS

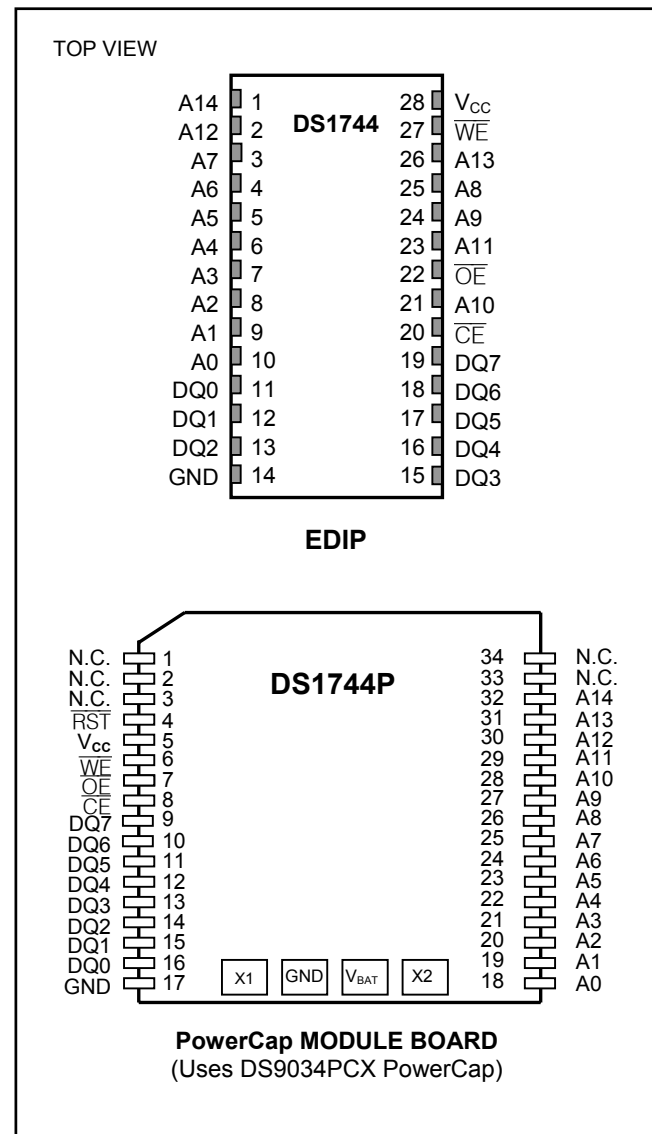

PowerCap is a registered trademark of Dallas Semiconductor.

**ORDERING INFORMATION**

PART	VOLTAGE (V)	TEMP RANGE	PIN-PACKAGE	TOP MARK**
DS1744-70	5.0	0°C to +70°C	28 EDIP	DS1744-70
DS1744-70+	5.0	0°C to +70°C	28 EDIP	DS1744+70
DS1744-70IND	5.0	-40°C to +85°C	28 EDIP	DS1744-70IND
DS1744-100+	5.0	0°C to +70°C	28 EDIP	DS1744+100
DS1744W-120	3.3	0°C to +70°C	28 EDIP	DS1744W-120
DS1744W-120+	3.3	0°C to +70°C	28 EDIP	DS1744W+120
DS1744W-120IND	3.3	-40°C to +85°C	28 EDIP	DS1744W-120IND
<b>DS1744P-70</b>	5.0	0°C to +70°C	34 PowerCap*	DS1744P-70
DS1744P-70+	5.0	0°C to +70°C	34 PowerCap*	DS1744P+70
DS1744P-70IND	5.0	-40°C to +85°C	34 PowerCap*	DS1744P-70IND
DS1744P-100+	5.0	0°C to +70°C	34 PowerCap*	DS1744P+100
DS1744WP-120	3.3	0°C to +70°C	34 PowerCap*	DS1744WP-120
DS1744WP-120+	3.3	0°C to +70°C	34 PowerCap*	DS1744WP+120
DS1744WP-120IND	3.3	-40°C to +85°C	34 PowerCap*	DS1744WP-120IND

+ Denotes a lead-free/RoHS-compliant device.

\*DS9034-PCX, DS9034I-PCX, DS9034-PCX+ required (must be ordered separately).

\*\* A "+" anywhere in the top mark denotes a lead-free device. An "IND" denotes an industrial temperature grade device.

**DESCRIPTION**

The DS1744 is a full-function, year-2000-compliant (Y2KC), real-time clock/calendar (RTC) and 32k x 8 NV SRAM. User access to all registers within the DS1744 is accomplished with a byte-wide interface as shown in Figure 1. The RTC information and control bits reside in the eight uppermost RAM locations. The RTC registers contain century, year, month, date, day, hours, minutes, and seconds data in 24-hour BCD format. Corrections for the date of each month and leap year are made automatically. The RTC clock registers are double-buffered to avoid access of incorrect data that can occur during clock update cycles. The double-buffered system also prevents time loss as the timekeeping countdown continues unabated by access to time register data. The DS1744 also contains its own power-fail circuitry that deselects the device when the  $V_{CC}$  supply is in an out-of-tolerance condition. This feature prevents loss of data from unpredictable system operation brought on by low  $V_{CC}$  as errant access and update cycles are avoided.

**ABSOLUTE MAXIMUM RATINGS**

Voltage Range on Any Pin Relative to Ground.....	-0.3V to +6.0V
Operating Temperature Range.....	-40°C to +85°C (noncondensing)
Storage Temperature Range.....	-40°C to +85°C (noncondensing)
Soldering Temperature.....	See IPC/JEDEC J-STD-020 Specification (EDIP, Note 7)

*This is a stress rating only and functional operation of the device at these or any other condition beyond those indicated in the operation sections of this specification is not implied. Exposure to absolute maximum rating conditions for extended periods of time can affect reliability.*

**OPERATING RANGE**

RANGE	TEMP RANGE	V <sub>CC</sub>
Commercial	0°C to +70°C, Noncondensing	3.3V ±10% or 5V±10%
Industrial	-40°C to +85°C, Noncondensing	3.3V ±10% or 5V±10%

**RECOMMENDED DC OPERATING CONDITIONS**

(T<sub>A</sub> = Over the operating range)

PARAMETER	SYMBOL	MIN	TYP	MAX	UNITS	NOTES
Logic 1 Voltage (All Inputs) V <sub>CC</sub> = 5V ±10% V <sub>CC</sub> = 3.3V ±10%	V <sub>IH</sub>	2.2		V <sub>CC</sub> + 0.3V	V	1
	V <sub>IH</sub>	2.0		V <sub>CC</sub> + 0.3V	V	
Logic 0 Voltage (All Inputs) V <sub>CC</sub> = 5V ±10% V <sub>CC</sub> = 3.3V ±10%	V <sub>IL</sub>	-0.3		0.8	V	
	V <sub>IL</sub>	0.3		0.6	V	1

**DC ELECTRICAL CHARACTERISTICS**

(V<sub>CC</sub> = 5.0V ±10%, T<sub>A</sub> = Over the operating range.)

PARAMETER	SYMBOL	MIN	TYP	MAX	UNITS	NOTES
Active Supply Current	I <sub>CC</sub>			75	mA	2, 3
TTL Standby Current ( $\overline{CE} = V_{IH}$ )	I <sub>CC1</sub>			6	mA	2, 3
CMOS Standby Current ( $\overline{CE} \geq V_{CC} - 0.2V$ )	I <sub>CC2</sub>			4	mA	2, 3
Input Leakage Current (Any Input)	I <sub>IL</sub>	-1		+1	μA	
Output Leakage Current (Any Output)	I <sub>OL</sub>	-1		+1	μA	
Output Logic 1 Voltage (I <sub>OUT</sub> = -1.0mA)	V <sub>OH</sub>	2.4				1
Output Logic 0 Voltage (I <sub>OUT</sub> = +2.1mA)	V <sub>OL</sub>			0.4		1
Write Protection Voltage	V <sub>PF</sub>	4.25		4.50	V	1
Battery Switchover Voltage	V <sub>SO</sub>		V <sub>BAT</sub>			1, 4

**DC ELECTRICAL CHARACTERISTICS**(V<sub>CC</sub> = 3.3V ±10%, T<sub>A</sub> = Over the operating range.)

PARAMETER	SYMBOL	MIN	TYP	MAX	UNITS	NOTES
Active Supply Current	I <sub>CC</sub>			30	mA	2, 3
TTL Standby Current ( $\overline{CE} = V_{IH}$ )	I <sub>CC1</sub>			2	mA	2, 3
CMOS Standby Current ( $\overline{CE} \geq V_{CC} - 0.2V$ )	I <sub>CC2</sub>			2	mA	2, 3
Input Leakage Current (Any Input)	I <sub>IL</sub>	-1		+1	μA	
Output Leakage Current (Any Output)	I <sub>OL</sub>	-1		+1	μA	
Output Logic 1 Voltage (I <sub>OUT</sub> = -1.0mA)	V <sub>OH</sub>	2.4				1
Output Logic 0 Voltage (I <sub>OUT</sub> = +2.1mA)	V <sub>OL</sub>			0.4		1
Write Protection Voltage	V <sub>PF</sub>	2.80		2.97	V	1
Battery Switchover Voltage	V <sub>SO</sub>		V <sub>BAT</sub> or V <sub>PF</sub>		V	1, 4

**AC CHARACTERISTICS—READ CYCLE (5V)**(V<sub>CC</sub> = 5.0V ±10%, T<sub>A</sub> = Over the operating range.)

PARAMETER	SYMBOL	MIN	TYP	MAX	UNITS	NOTES
Read Cycle Time	t <sub>RC</sub>	70			ns	
Address Access Time	t <sub>AA</sub>			70	ns	
$\overline{CE}$ to DQ Low-Z	t <sub>CEL</sub>	5			ns	
$\overline{CE}$ Access Time	t <sub>CEA</sub>			70	ns	
$\overline{CE}$ Data Off Time	t <sub>CEZ</sub>			25	ns	
$\overline{OE}$ to DQ Low-Z	t <sub>OEL</sub>	5			ns	
$\overline{OE}$ Access Time	t <sub>OEA</sub>			35	ns	
$\overline{OE}$ Data Off Time	t <sub>OEZ</sub>			25	ns	
Output Hold from Address	t <sub>OH</sub>	5			ns	

### AC CHARACTERISTICS—READ CYCLE (3.3V)

( $V_{CC} = 3.3V \pm 10\%$ ,  $T_A =$  Over the operating range.)

PARAMETER	SYMBOL	MIN	TYP	MAX	UNITS	NOTES
Read Cycle Time	$t_{RC}$	120			ns	
Address Access Time	$t_{AA}$			120	ns	
$\overline{CE}$ to DQ Low-Z	$t_{CEL}$	5			ns	
$\overline{CE}$ Access Time	$t_{CEA}$			120	ns	
$\overline{CE}$ Data Off Time	$t_{CEZ}$			40	ns	
$\overline{OE}$ to DQ Low-Z	$t_{OEL}$	5			ns	
$\overline{OE}$ Access Time	$t_{OEA}$			100	ns	
$\overline{OE}$ Data Off Time	$t_{OEZ}$			35	ns	
Output Hold from Address	$t_{OH}$	5			ns	

### READ CYCLE TIMING DIAGRAM

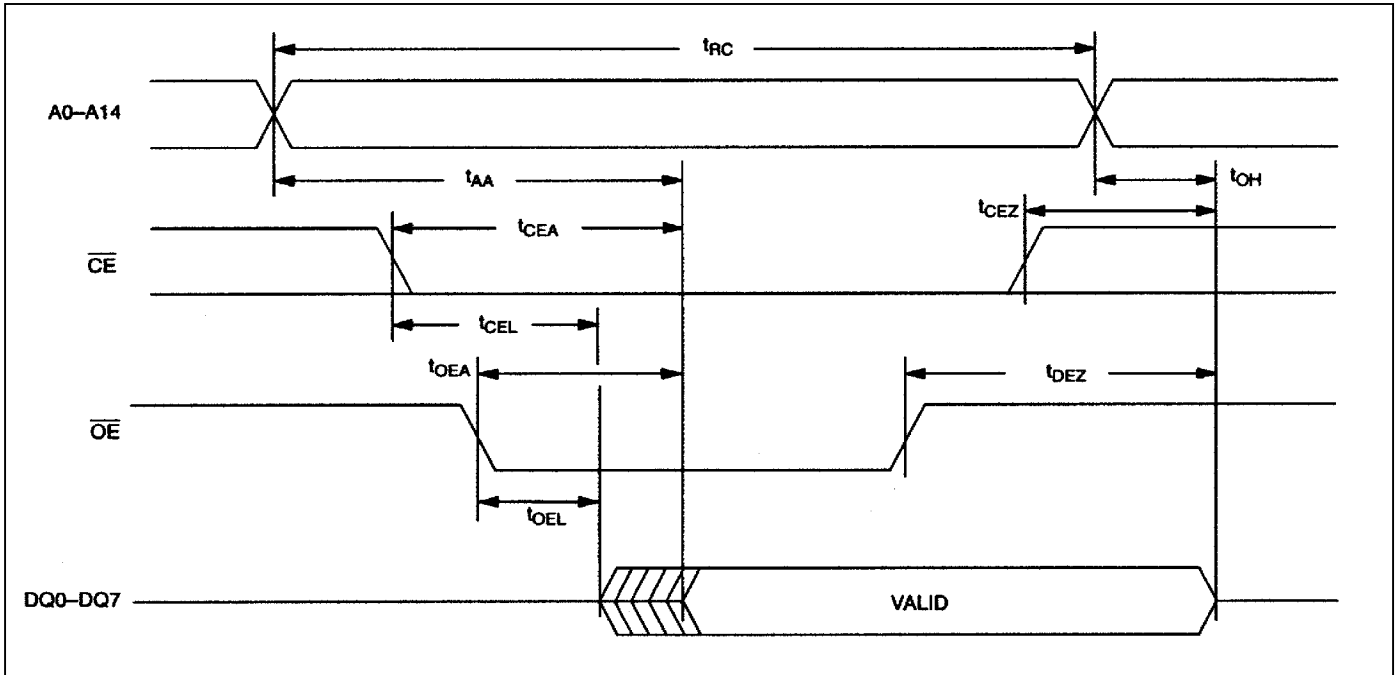

**AC CHARACTERISTICS—WRITE CYCLE (5V)**(V<sub>CC</sub> = 5.0V ±10%, T<sub>A</sub> = Over the operating range.)

PARAMETER	SYMBOL	MIN	TYP	MAX	UNITS	NOTES
Write Cycle Time	t <sub>WC</sub>	70			ns	
Address Setup Time	t <sub>AS</sub>	0			ns	
$\overline{\text{WE}}$ Pulse Width	t <sub>WEW</sub>	50			ns	
$\overline{\text{CE}}$ Pulse Width	t <sub>CEW</sub>	60			ns	
Data Setup Time	t <sub>DS</sub>	30			ns	
Data Hold Time	t <sub>DH1</sub>	0			ns	8
Data Hold Time	t <sub>DH2</sub>	0			ns	9
Address Hold Time	t <sub>AH1</sub>	5			ns	8
Address Hold Time	t <sub>AH2</sub>	5			ns	9
$\overline{\text{WE}}$ Data Off Time	t <sub>WEZ</sub>			25	ns	
Write Recovery Time	t <sub>WR</sub>	5			ns	

**AC CHARACTERISTICS—WRITE CYCLE (3.3V)**(V<sub>CC</sub> = 3.3V ±10%, T<sub>A</sub> = Over the operating range.)

PARAMETER	SYMBOL	MIN	TYP	MAX	UNITS	NOTES
Write Cycle Time	t <sub>WC</sub>	120			ns	
Address Setup Time	t <sub>AS</sub>	0		120	ns	
$\overline{\text{WE}}$ Pulse Width	t <sub>WEW</sub>	100			ns	
$\overline{\text{CE}}$ Pulse Width	t <sub>CEW</sub>	110			ns	
$\overline{\text{CE}}$ and CE2 Pulse Width	t <sub>CEW</sub>	110			ns	
Data Setup Time	t <sub>DS</sub>	80			ns	
Data Hold Time	t <sub>DH1</sub>	0			ns	8
Data Hold Time	t <sub>DH2</sub>	0			ns	9
Address Hold Time	t <sub>AH1</sub>	0			ns	8
Address Hold Time	t <sub>AH2</sub>	10			ns	9
$\overline{\text{WE}}$ Data Off Time	t <sub>WEZ</sub>			40	ns	
Write Recovery Time	t <sub>WR</sub>	10			ns	

**POWER-UP/DOWN AC CHARACTERISTICS (5V)**

( $V_{CC} = 5.0V \pm 10\%$ ,  $T_A =$  Over the operating range.)

PARAMETER	SYMBOL	MIN	TYP	MAX	UNITS	NOTES
$\overline{CE}$ or $\overline{WE}$ at $V_{IH}$ Before Power-Down	$t_{PD}$	0			$\mu s$	
$V_{CC}$ Fall Time: $V_{PF(MAX)}$ to $V_{PF(MIN)}$	$t_F$	300			$\mu s$	
$V_{CC}$ Fall Time: $V_{PF(MIN)}$ to $V_{SO}$	$t_{FB}$	10			$\mu s$	
$V_{CC}$ Rise Time: $V_{PF(MIN)}$ to $V_{PF(MAX)}$	$t_R$	0			$\mu s$	
Power-Up Recover Time	$t_{REC}$			35	ms	
Expected Data-Retention Time (Oscillator ON)	$t_{DR}$	10			years	5, 6

**POWER-UP/DOWN TIMING (5V DEVICE)**

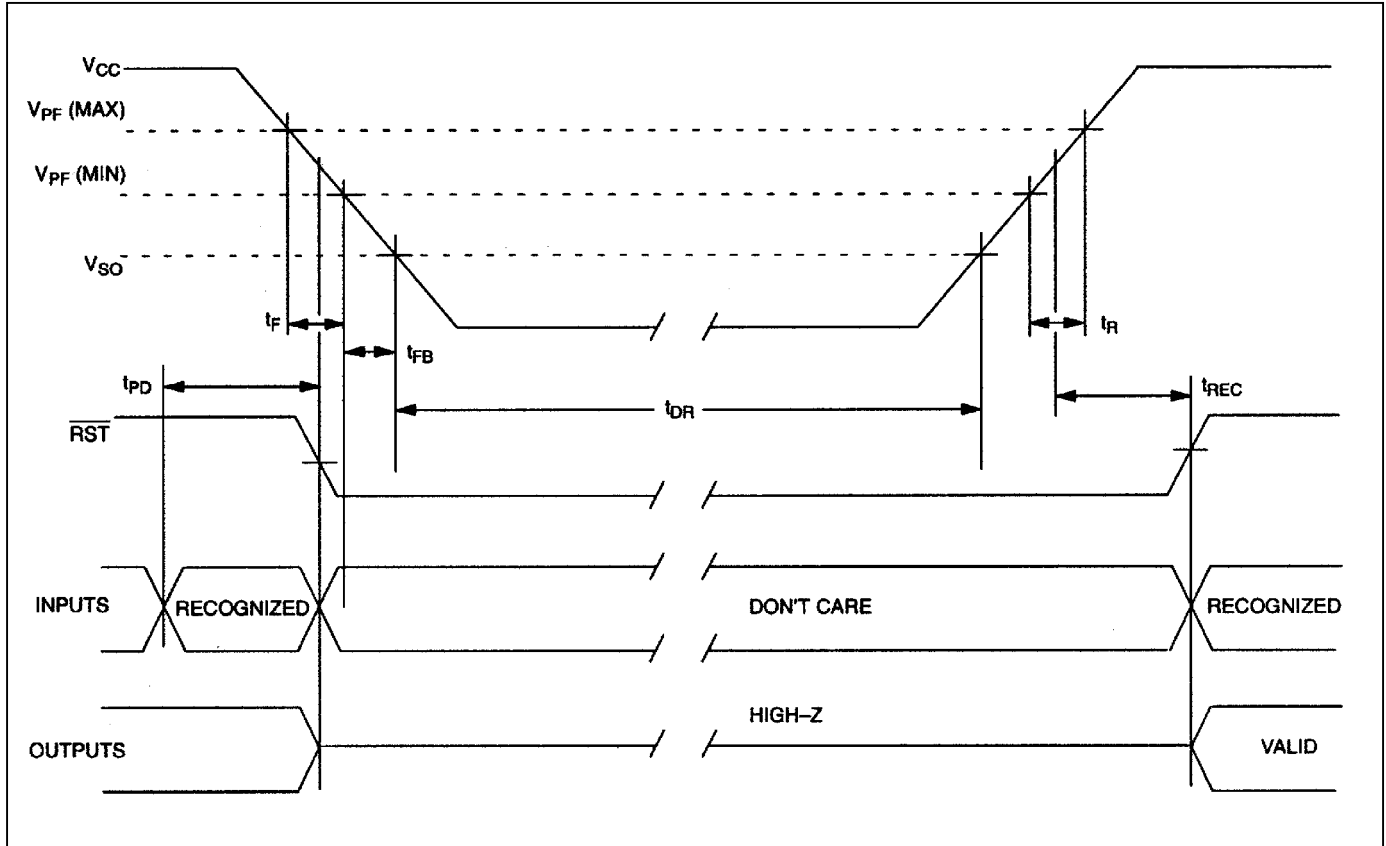

**POWER-UP/DOWN CHARACTERISTICS (3.3V)** $(V_{CC} = 3.3V \pm 10\%, T_A = \text{Over the operating range.})$ 

PARAMETER	SYMBOL	MIN	TYP	MAX	UNITS	NOTES
$\overline{CE}$ or $\overline{WE}$ at $V_{IH}$ , Before Power-Down	$t_{PD}$	0			$\mu\text{s}$	
$V_{CC}$ Fall Time: $V_{PF(MAX)}$ to $V_{PF(MIN)}$	$t_F$	300			$\mu\text{s}$	
$V_{CC}$ Rise Time: $V_{PF(MIN)}$ to $V_{PF(MAX)}$	$t_R$	0			$\mu\text{s}$	
$V_{PF}$ to $\overline{RST}$ High	$t_{REC}$			35	ms	
Expected Data-Retention Time (Oscillator ON)	$t_{DR}$	10			years	5, 6

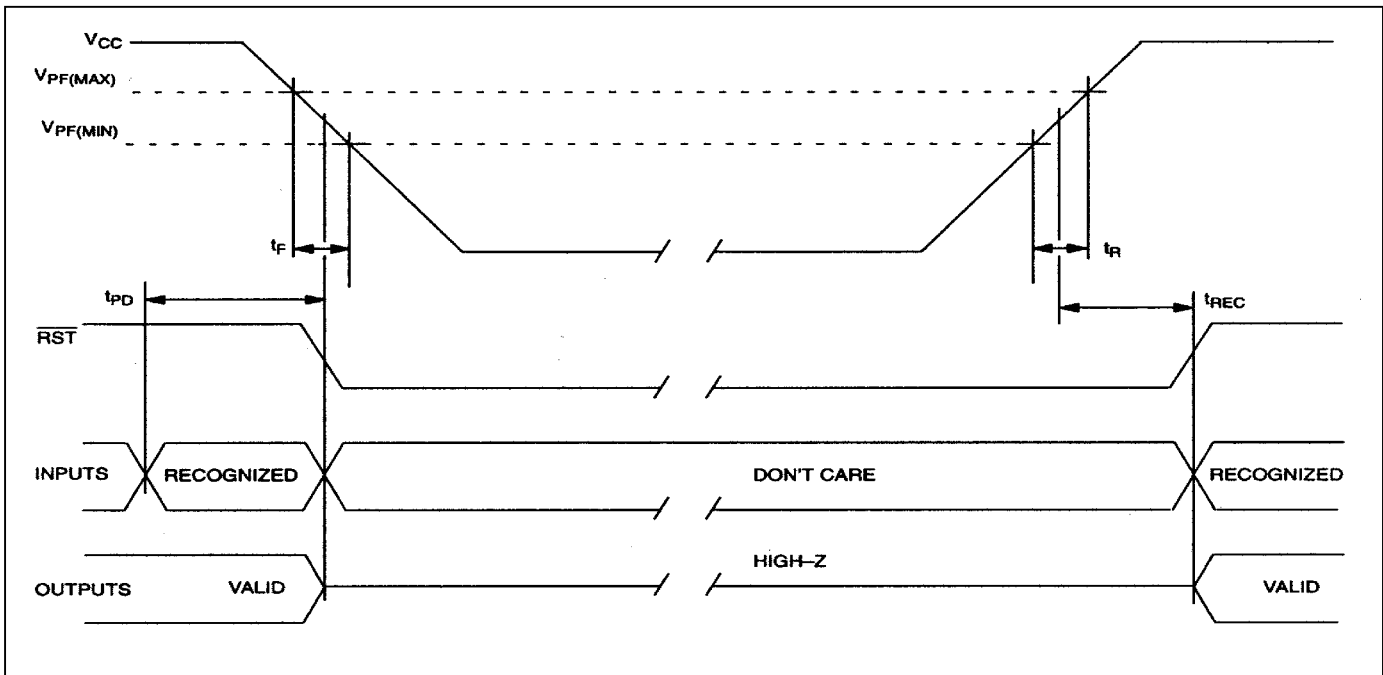
**POWER-UP/DOWN WAVEFORM TIMING (3.3V DEVICE)****CAPACITANCE** $(T_A = +25^\circ\text{C})$ 

PARAMETER	SYMBOL	MIN	TYP	MAX	UNITS	NOTES
Capacitance On All Input Pins	$C_{IN}$			14	pF	
Capacitance On All Output Pins	$C_O$			10	pF	



## AC TEST CONDITIONS

Output Load: 50pF + 1TTL Gate

Input Pulse Levels: 0 to 3.0V

Timing Measurement Reference Levels:

Input: 1.5V

Output: 1.5V

Input Pulse Rise and Fall Times: 5ns

## NOTES:

- 1) Voltages are referenced to ground.
- 2) Typical values are at +25°C and nominal supplies.
- 3) Outputs are open.
- 4) Battery switchover occurs at the lower of either the battery terminal voltage or  $V_{PF}$ .
- 5) Data-retention time is at +25°C.
- 6) Each DS1744 has a built-in switch that disconnects the lithium source until the user first applies  $V_{CC}$ . The expected  $t_{DR}$  is defined for DIP modules and assembled PowerCap modules as a cumulative time in the absence of  $V_{CC}$  starting from the time power is first applied by the user.
- 7) RTC modules (DIP) can be successfully processed through conventional wave-soldering techniques as long as temperature exposure to the lithium energy source contained within does not exceed +85°C. Post-solder cleaning with water-washing techniques is acceptable, provided that ultrasonic vibration is not used.

In addition, for the PowerCap:

- a.) Dallas Semiconductor recommends that PowerCap module bases experience one pass through solder reflow oriented with the label side up (“live-bug”).
  - b.) Hand soldering and touch-up: Do not touch or apply the soldering iron to leads for more than 3 seconds. To solder, apply flux to the pad, heat the lead frame pad, and apply solder. To remove the part, apply flux, heat the lead frame pad until the solder reflows, and use a solder wick to remove solder.
- 8)  $t_{AH1}$ ,  $t_{DH1}$  are measured from  $\overline{WE}$  going high.
  - 9)  $t_{AH2}$ ,  $t_{DH2}$  are measured from  $\overline{CE}$  going high.